

Differential Bush Removal & Installation Tool Kit - for

The BMW models listed are all rear wheel drive. The rear differential mounting bushes have a stressful job, maintaining both the position of the rear differential and isolating the occupants of the vehicle from unwanted noise and vibration. Sooner or later all rubber mounts will fail. As the bushes start to degrade, the differential can move around putting increased stress on all the associated components (differential internals, prop shafts, drive shaft and suspension components) leading to a vehicle that feels and sounds like it is falling apart! The Laser 8406 bush kit is designed to allow the user to quickly and easily remove the old bushes and fit new ones, all while the subframe remains in the car.



Additional Information

- Applications include: BMW 1 Series (2004 - 2014), 3 Series (2005 - 2014) & Z4 (2003 - 2009).
- BMW chassis references: E81, E82, E83, E84, E85, E86, E87, E88, E90, E91, E92 & E93.
- Designed to remove and fit both front and rear bushes on the rear differential.
- Equivalent to OEM 33 3 312, 33 4 161, 33 4 162, 33 4 166, 33 4 311, 33 4 312, 33 42 81, 33 4 351, 33 4 357, 33 4 358, 33 4 465 & 33 4 466.
- Ensure all force screws are lubricated with molybdenum disulphide grease. Use hand tools only.

<http://lasertools.co.uk/product/8406>

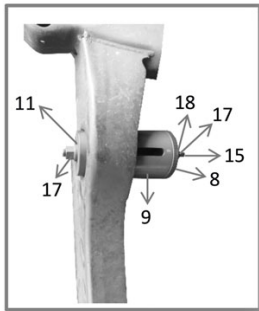

Removal-Rear

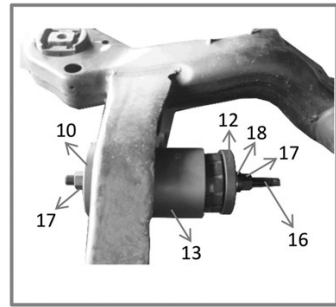

Installation- Rear

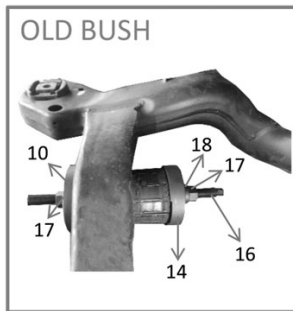

Installation- Rear

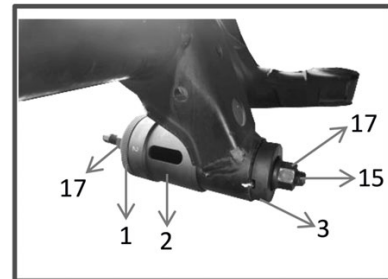

Removal-Front

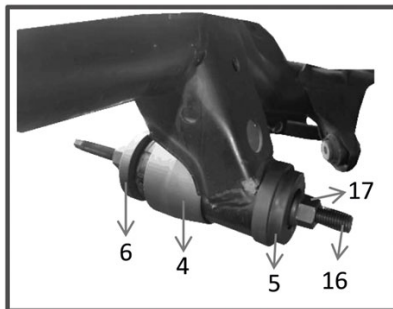

Installation-Front

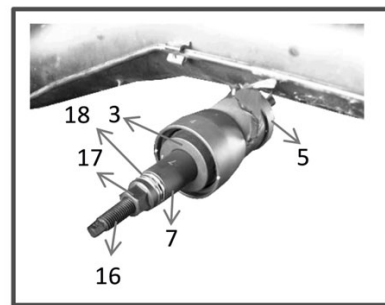

Installation-Front